

How To Identify a 4" Mercury Crankshaft

by Bill Boomer, aka Flatcat, aka 4tford

The intent of this article is to enable you to identify the crankshaft you are looking at as either a **Mercury 4" stroke** or a **Ford 3-3/4" stroke**. I will try and describe to you what to do to make a somewhat positive identification and then the pictures can be used to clear up what is foggy.

The 4" stroke crank in North America came in the Mercury vehicles from 1949 to 1953 in the United States and to 1954 in Canada. The Fords were 3-3/4" stroke in both countries.

Because Henry Ford did many different things in many different unexplained ways, the only positive way to identify the crank is to measure the stroke.

If the motor is in the vehicle and you are able to remove a head and rotate the engine, it is a simple matter. Rotate the engine so one piston is at the top of a stroke. Mark the location of the piston and then rotate the same piston to the bottom of its stroke and measure the distance the piston went. If it went 3-3/4" it is Ford and if it went 4" it is Mercury. Another way for a quick check, but not a guaranteed method is to remove the oil pan and measure across the widest part of the thickest counterweight. If the measurement is about 6" it should be Mercury. If it is about 5-1/2" it should be Ford. If the cleanout holes are 5/8" then it should be American made Mercury and I have seen numerous American made Mercury. Cranks with a 3/8" cleanout plug. If the letters EAC, 1CM or 0CM they should be Mercury as these are known to be Mercury symbols. I use the word "should" a lot because the only positive method is to measure the actual stroke.

99% of the Canadian made 4" stroke cranks had a 3/8" cleanout as well as an approximately 7/8" long kidney shaped dimple recessed into either one or both of the first thin counterweights. Again, this is not a guarantee but a very strong indicator.

Now on to the pictures. I hope they are self explanatory





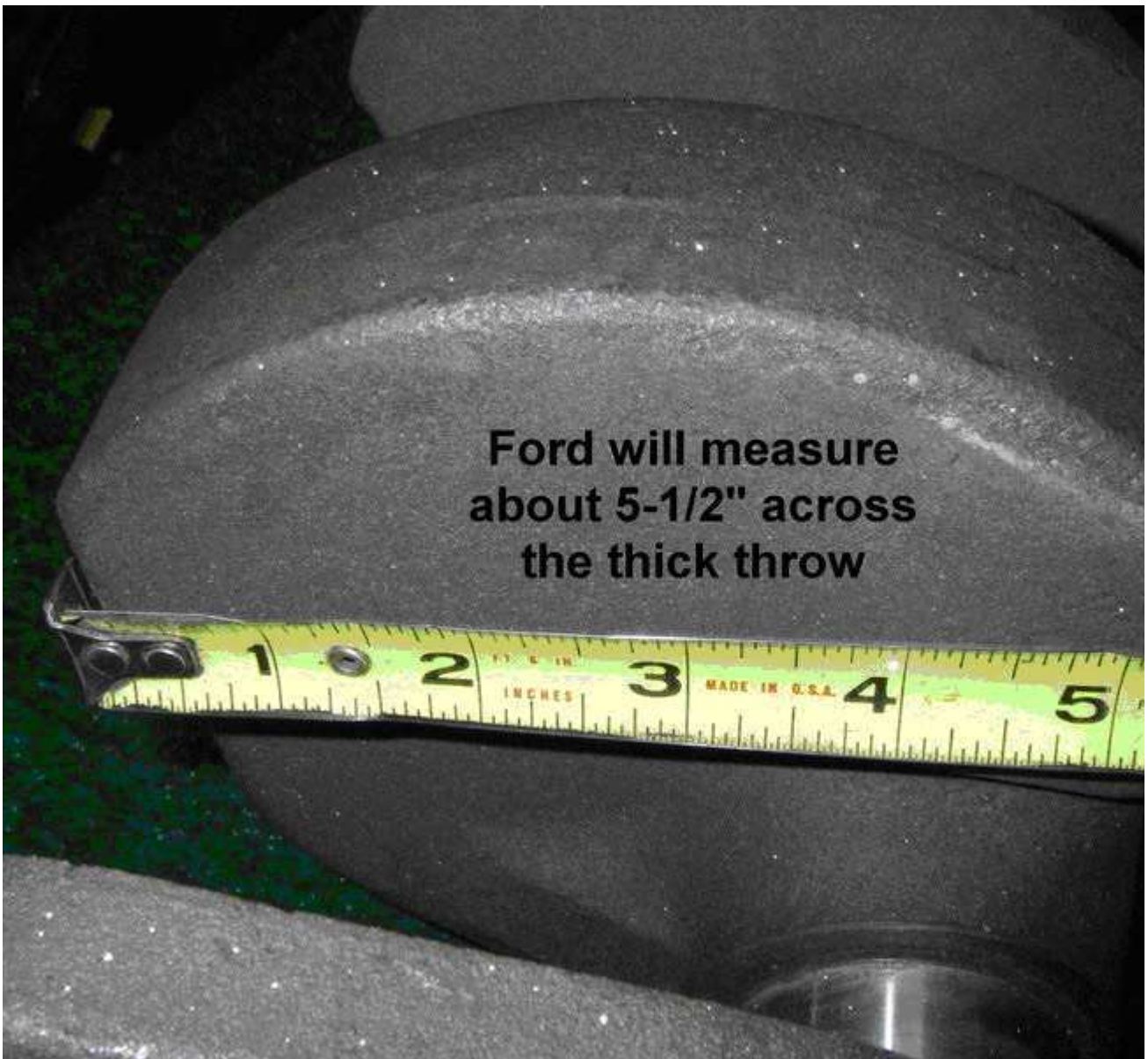



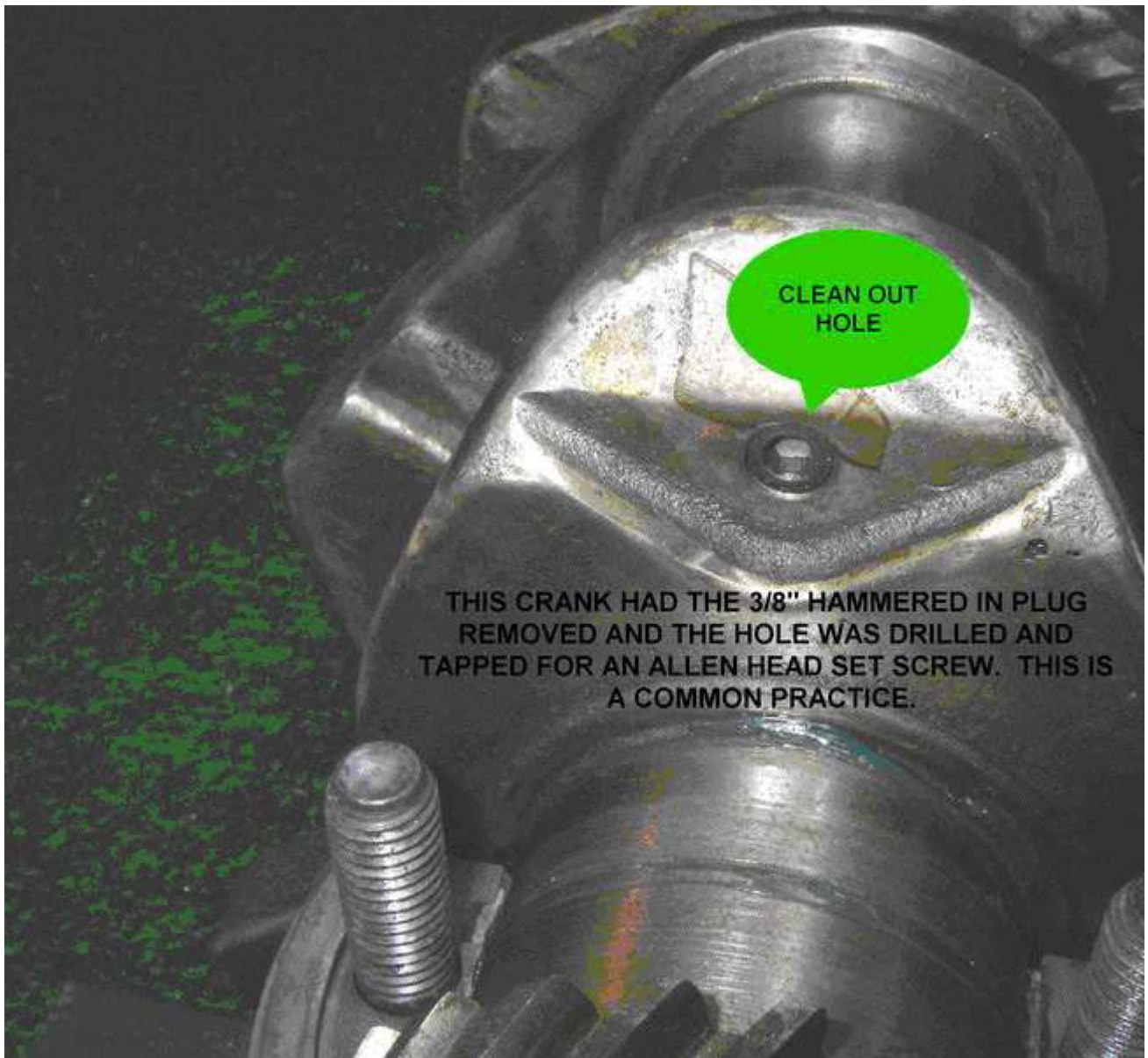

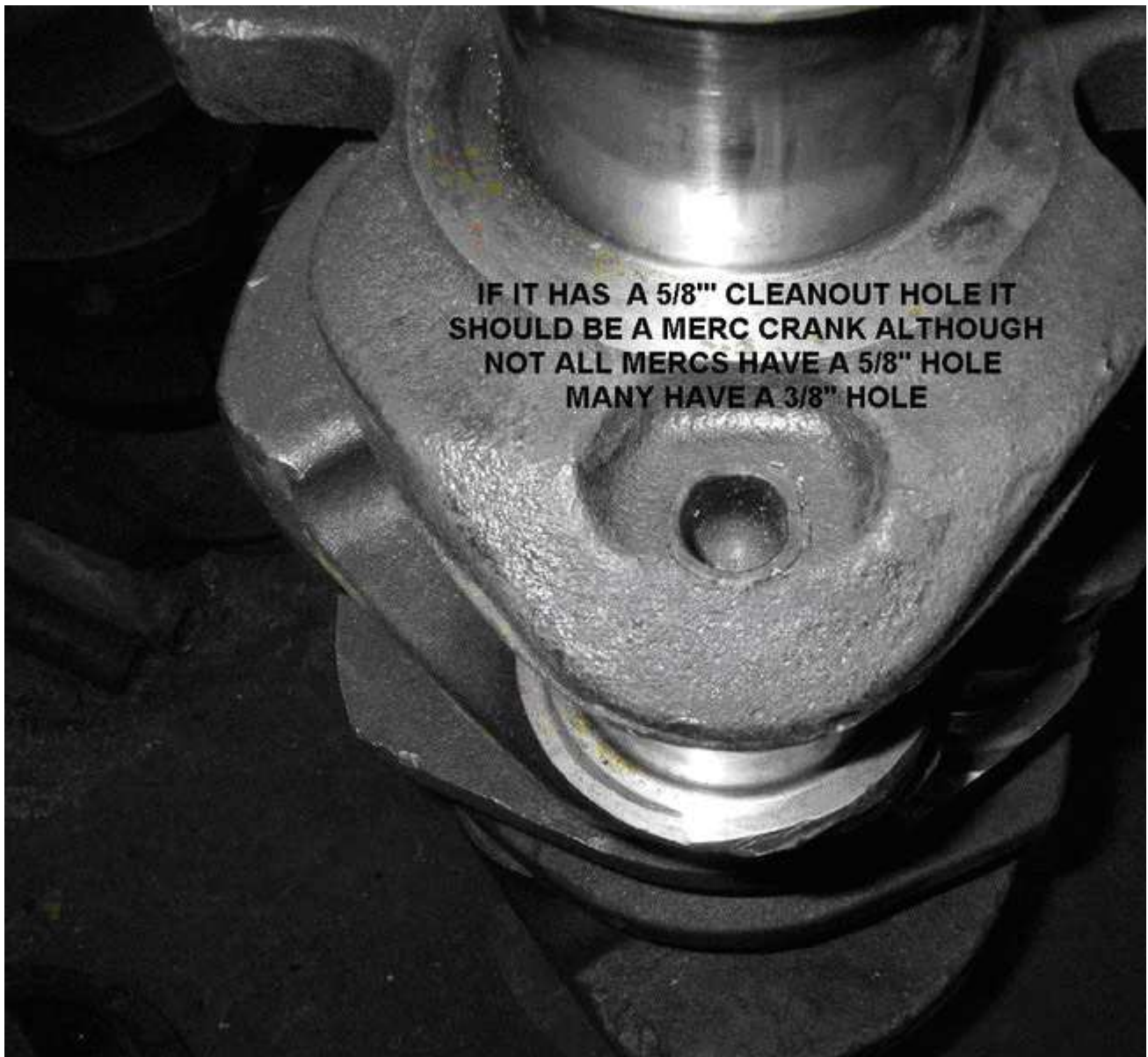

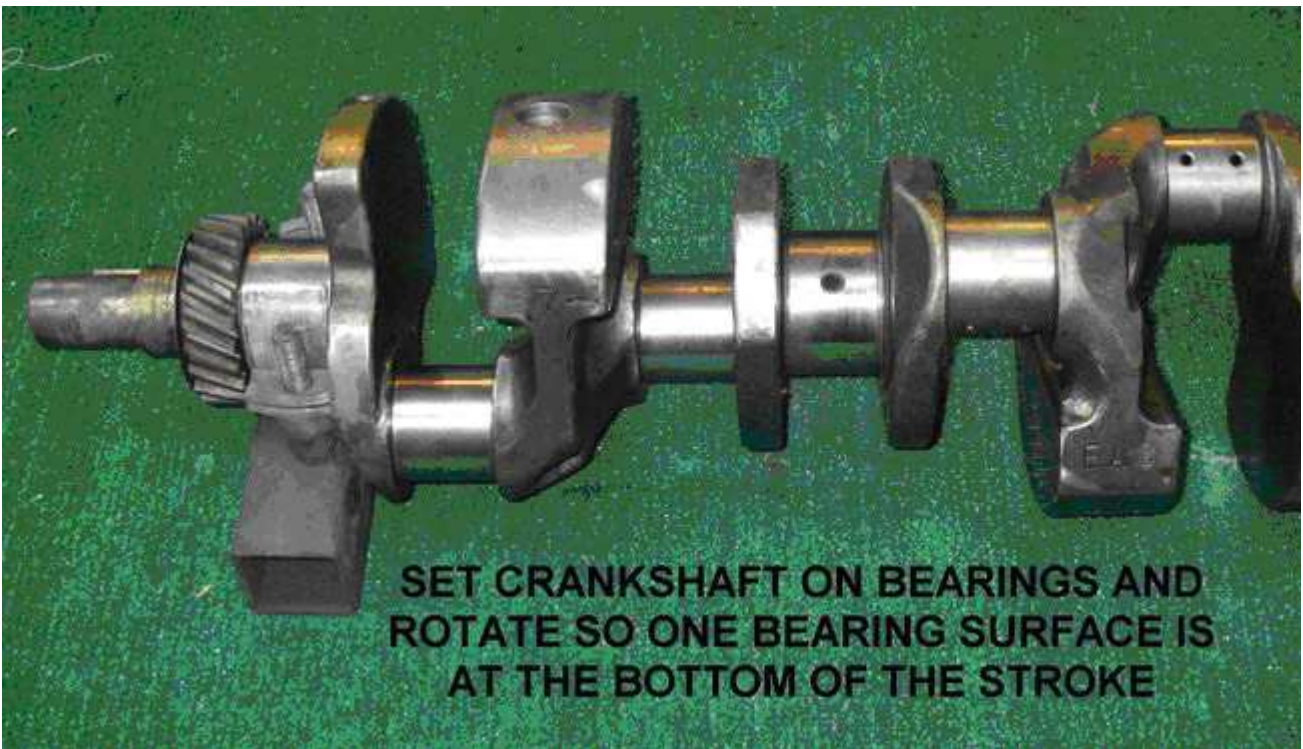
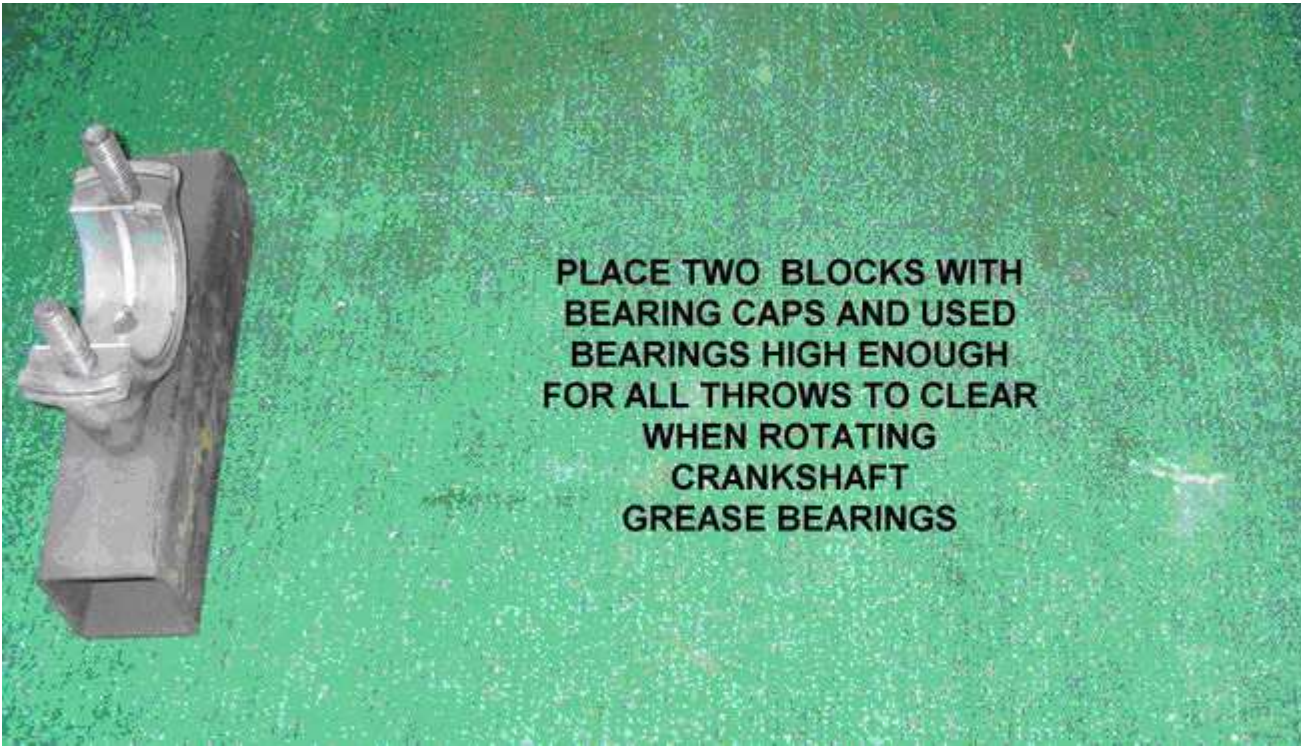

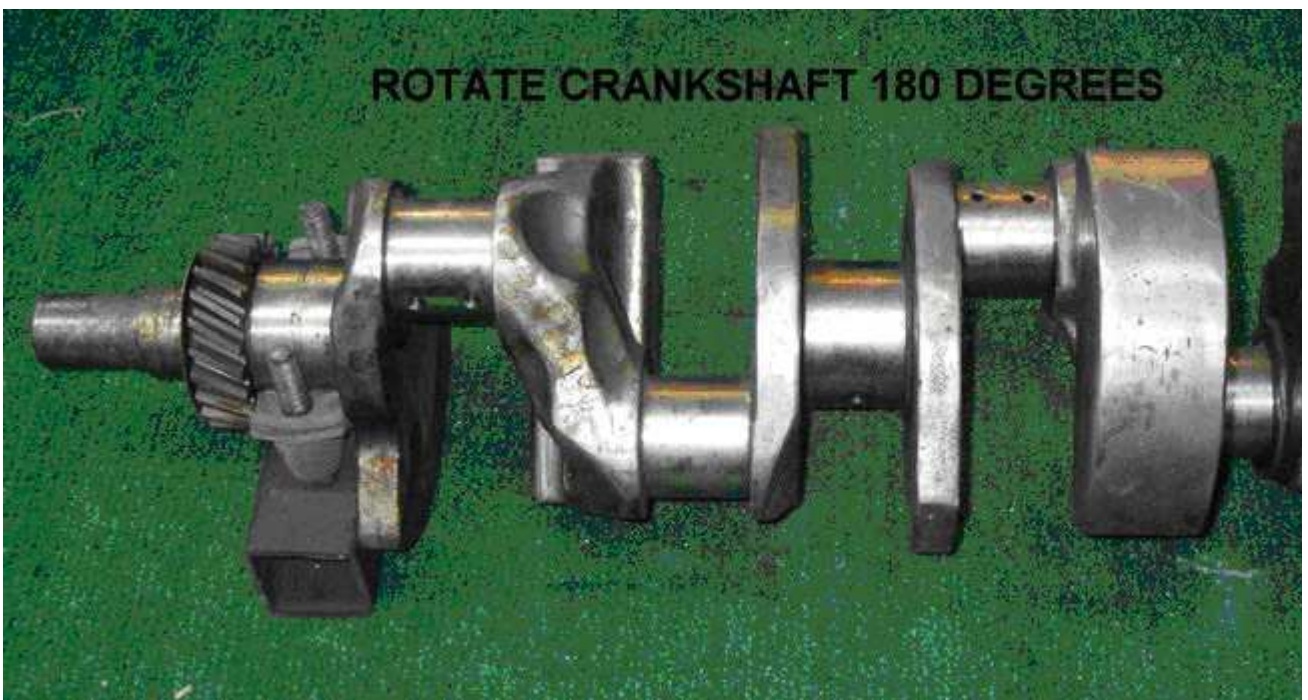
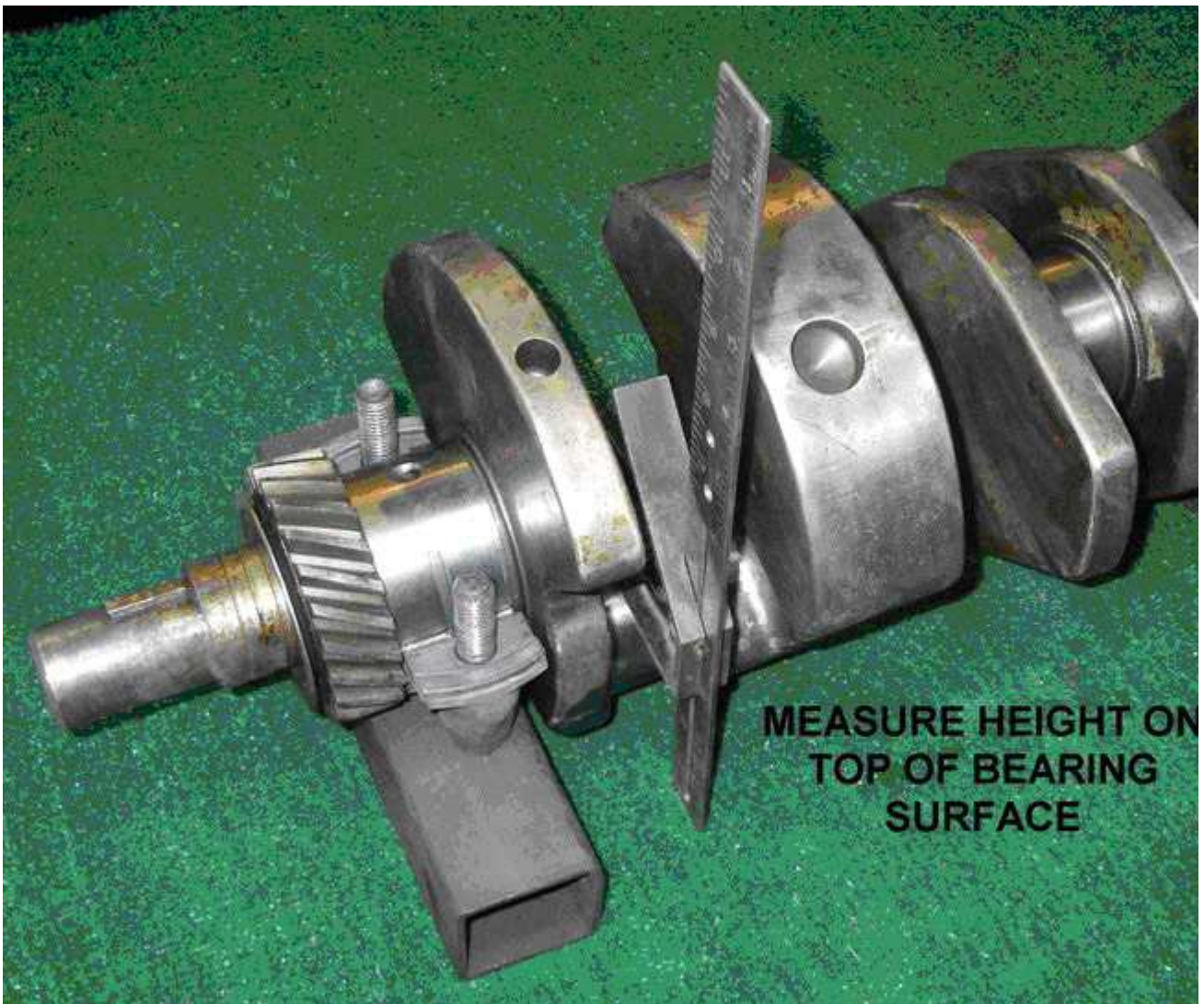

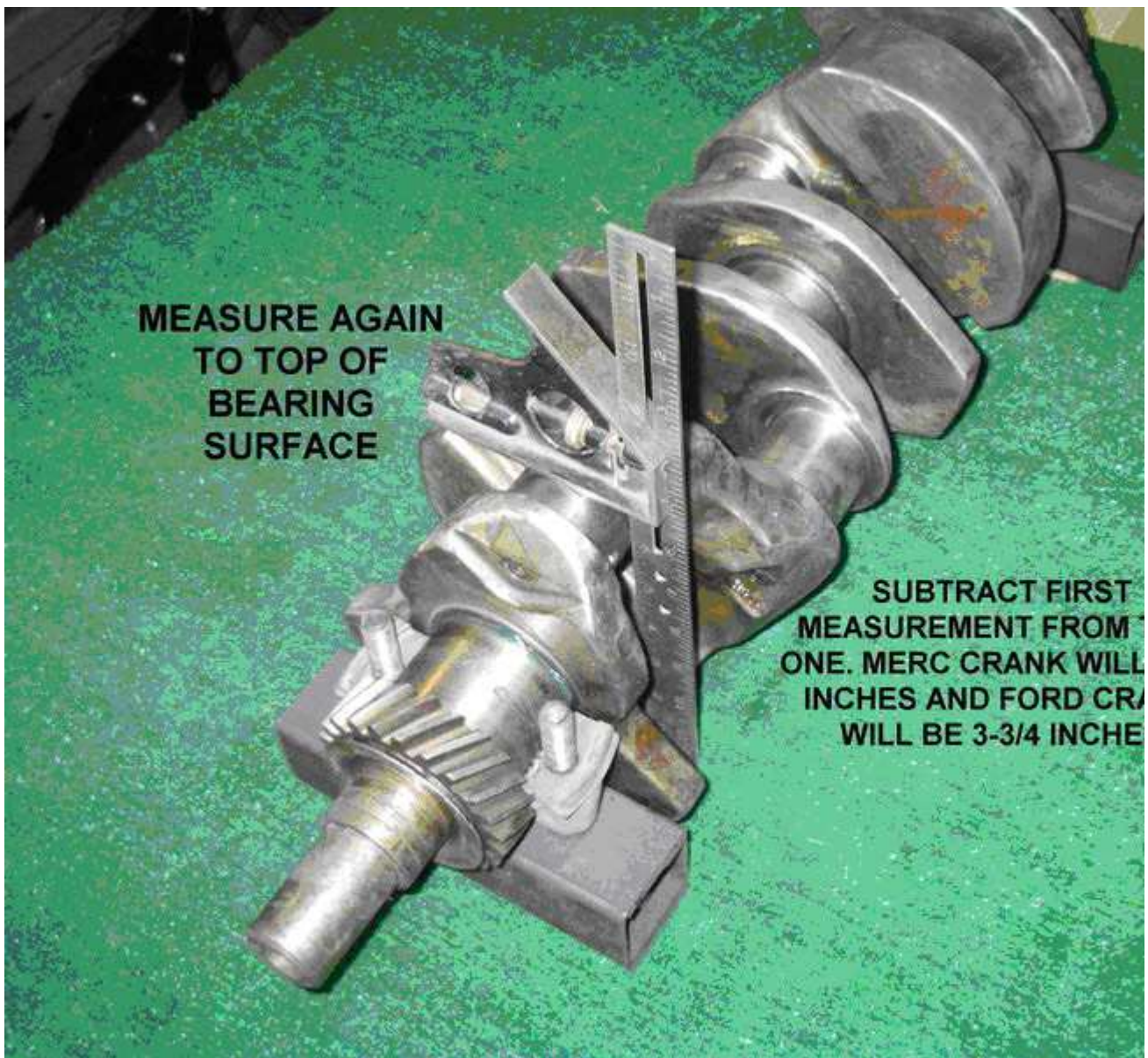

Article created by Bill Boomer (4tford) 11/2007